

Optimization of media composition for keratinase production on feather by *Acremonium strictum* RKS1

Jitendra Kumar and R K S Kushwaha

Department of Botany, Christ Church College, Kanpur-208001, India

ABSTRACT

*Five-level-five factors concept was utilized for the optimization for keratinase production by *Acremonium strictum* RKS1. Experiments were performed as a function Duration, pH, Amount of substrate, Nitrogen source and Carbon source. Optimization of these five parameters for the maximum production of keratinase was studied. Statistically designed experiment using response surface methodology was used to get more information about the significant effect and the interaction between the five parameters. 2ⁿ full factorial central composite design was employed for the experimental design and analysis of result. The optimum process condition for maximum enzyme production as follows: Duration 12.8 day, 10 pH, Amount of substrate 199mg, Nitrogen source 3.5% and Carbon source 3%. The maximum keratin production was achieved (92.7%) at the optimum process conditions.*

Keywords: Keratinase, RSM, CCD etc

INTRODUCTION

Keratinase is a group of proteolytic enzymes hydrolyzing insoluble keratins, more efficiently than other proteases. It belongs to group of serine protease. The keratinases are produced by some species of *Bacillus* (Bressollier et al., 1999), some actinomycetes (Bockle et al., 1995) and fungi (Kushwaha, 1983). There are relatively few reports are available on keratinase of nondermatophytic fungi.

Although keratinase from dermatophytic fungi have long been well known due to their notorious pathogenic nature (Sohnle and Wagner 2000). These groups of enzymes have only recently gained biotechnological impetus. Their growing importance is mainly contributed to the isolation of keratinase from non pathogenic microorganism and their ability to degrade the tough insoluble keratin of feather and convert it into economically useful feather meal (Onifade et al., 1998; Lin et al., 1999; Riffle et al., 2003), nitrogenous fertilizers, biodegradable films, glues, and foils (Friedrich et al., 1996; Schrooyen et al., 2001; De Toni et al., 2002).

Response surface methodology (RSM) has been widely used in the empirical study of the relationship between one or more measured response such as yield, on one hand, and a number of input variables such as time, temperature and concentration on the other hand (Rao et al., 2000; Elibol et al., 2002). Empirical models and statistical analysis are extremely important to elucidate basic mechanism in complex situation, thus providing better process control and understanding. In most RSM problems the form of the relationship between response and the independent variables is unknown. Thus the first step in RSM is to approximate the process to a function (f) in some region of the independent variables. If the response is well modeled by a linear function of independent variables, then the approximately function is a first-order model. If there is curvature in the system or in the optimum region, then a polynomial of higher degree, such as a second-order model, must be used to approximate the response. The main objective of RSM is to determine the optimum operational conditions for the system or to determine a region that satisfies the operating specifications (Hasmann et al., 1999; Carla and Roberto 2001; Ferreira et al., 2007; Techapun et al., 2002; Box et al., 1978; Box and Draper 1987).

Some good examples of appropriate application of this technique in lipase production (Agarry *et al.*, 2008), production of microbial enzymes (Anustrup *et al.*, 1979), microbial degradation of phenol by *Pseudomonas aeruginosa* (Elibol and Ozer 2002) etc., are the optimization of process variables.

It is evident from the literature that no work has been reported so far as for the optimization of process variables of the keratinase production from *Acremonium strictum* fungi. The present investigation was, therefore, undertaken to optimize the process variables viz., duration, pH, amount of substrate, nitrogen source and carbon source, for the production of keratinase using RSM by adopting a five-level, five-factor central composite rotatable design (CCRD). Second- order model was used to generate three-dimensional response surfaces for the keratinase production.

MATERIALS AND METHODS

2.1. Isolation method

The fungus strain *Acremonium strictum* RKS1 isolated from soil sample collected from cattle field using Hair baiting method (Benedek, 1962) was used for the present study.

2.2. Method for the keratinase production

The keratinase were measured by using the method of Ramnani and Gupta (2004) with some modifications which are as follows. For enzyme production a modified production medium were used which contained the following; 05% whole chicken feather ; 0.2% glucose 0.5% peptone; 0.5% yeast extract; 0.1 % K_2HPO_4 ; 0.3% KH_2PO_4 ; 0.1% $CaCl_2$ and 0.1% $MgSO_4$. The above medium dispensed in 250 ml. Erlenmeyer flasks and sterilized by autoclaving at $121^\circ C$ for 20 min. Each flask was inoculated at $28 \pm 2^\circ C$ under shaking (250 rev. / min) for 2 hour daily up to 8 days. Thereafter the culture broth obtained was filtered and the cell free supernatant was then be used for assays.

2.3. Analytical method for keratinase production

Keratinase activities were measured by the method described by Dozie *et al.*, (1994). The reaction mixture containing 1 ml. of appropriately diluted enzyme, 4 ml of NaOH buffer (0.05 M, pH 10) and 20 mg of feather were incubated at $60^\circ C$ for 60 min. The reaction were terminated by adding 4 ml of 5% (w/v) Trichloroacetic acid and the tubes were incubated for 60 min at room temp. The feather and insoluble residue were removed by filtration through glass wool and the control was prepared in a similar manner, except that 1 ml of 5% Trichloroacetic acid and 3 ml of the buffer were added instead of 4 ml. of the buffer used in the test. Keratinase activity was determined by reading at 280nm against controls using UV-1700 Shimadzu UV-Visible spectrophotometer. One unit (U/mL) of keratinase activity was defined as an increase of absorbance of 0.01 at 280 nm.

2.4. Experimental Design

Response surface methodology (RSM) is a collection of mathematical and statistical techniques that are useful for the modeling and analysis of problems in which a response of interest is influenced by several variables and the objective is to optimize this response. This approach to optimizing processes supports Taguchi's philosophy, but provides simple and more efficient methods that are easier to learn and apply to carry this philosophy into practice (Kumar *et al.*, 2000; Grum and Slabe 2004; Rao *et al.*, 2000; Dasu and Panda 2000; Souza *et al.*, 1999).

In this study, the effect of five independent variables in enzyme production system can be investigated by using rotatable central composite design (CCD), which is one of the designs in response surface methodology design for the determination of quantitative relationship between the response function and the process (Chow and Yap 2008). A 2^2 full factorial central composite design with five coded levels leading to thirty two sets of experiment was performed (Montgomery 1991). For statistical calculation, the variables were coded according to eq. 1 (Box and Behnken 1960; Box and Draper 1959; Maddox and Richert 1977).

$$X_i = \frac{x_i - x_{i0}}{\Delta x_i} \text{----- (1)}$$

Where X_i is the independent variable coded value, x_i the corresponding independent variable actual value, x_{i0} the independent variable actual value on the center point and Δx_i is the step change value.

Maximal keratinase production was investigated using a central composite design (CCD) with five variables (Cochran and Cox 1959). This experiment design was considered appropriate since non- linear trends under study. The processing variables of duration, pH, amount of substrate, nitrogen source and carbon source were chosen for the CCD experiments.

The study is based on the hypothesis that the keratinase production is functionally related to process variables and attempts to fit a multiple regression equation describing the response, i.e., *p*. Table 1 lists variables in the descending order of assumed importance as process variables.

Table 1 : Variables and their levels for central composite design

Independent Variables	Symbols		Levels				
	Coded	Actual	-2	-1	0	+1	+2
Duration (days)	^a X ₁	x ₁	4	8	12	16	20
pH	^b X ₂	x ₂	8.5	9.0	9.5	10	10.5
Amount of substrate (mg)	^c X ₃	x ₃	100	150	200	250	300
Nitrogen source (%)	^d X ₄	x ₄	3	4	5	6	7
Carbon source (%)	^e X ₅	x ₅	1	1.5	2	2.5	3

The design is dependent up on the symmetrical selection of variation increments about the central composition. These levels of variation were chosen to be within the reasonable range, since interpretation of the result was validously within the experimental limits. The levels selected were also based on the conclusion of previous studies. The increments of variation for each variable spaced around the center point along with the equation relating the actual and coded ratios are presented in Table 1.

Table 2 : Central Composite Design Arrangement and Response.

Experiment No.	Variable Levels					Keratinase production p
	X ₁	X ₂	X ₃	X ₄	X ₅	
1	-1	1	-1	1	1	0.63
2	-2	0	0	0	0	0.51
3	0	2	0	0	0	0.69
4	0	0	0	0	-2	0.94
5	0	0	-2	0	0	0.56
6	-1	-1	-1	1	-1	0.56
7	-1	-1	1	-1	-1	0.63
8	-1	1	-1	-1	-1	0.57
9	1	1	1	-1	-1	0.71
10	1	-1	1	1	-1	0.66
11	0	-2	0	0	0	1.10
12	0	0	0	2	0	0.95
13	-1	-1	1	1	1	0.83
14	0	0	2	0	0	0.56
15	1	-1	-1	1	1	0.78
16	1	1	1	1	1	0.67
17	2	0	0	0	0	0.66
18	1	-1	-1	-1	-1	0.65
19	-1	-1	-1	-1	1	0.73
20	0	0	0	-2	0	0.80
21	1	1	-1	-1	1	0.68
22	-1	1	1	-1	1	0.63
23	-1	1	1	1	-1	0.83
24	1	-1	1	-1	1	0.79
25	0	0	0	0	2	0.92
26	1	1	-1	1	-1	0.94
27	0	0	0	0	0	0.78
28	0	0	0	0	0	0.80
29	0	0	0	0	0	0.82
30	0	0	0	0	0	0.78
31	0	0	0	0	0	0.84
32	0	0	0	0	0	0.79

As shown in Table 2, a set of 32 experiments was carried out. All variables were taken at a central coded value set at zero. The minimum and maximum ranges of the variables and full experimental plan with respect to their values in coded forms are also listed in Table 2. Upon completion of the experiments, keratinase production was taken as the response (*Y*). A second-order polynomial equation was then fitted to the data by a multiple regression procedure. The equation resulted in an empirical model that relates the measured response to the independent variables of the experiment. When several factors are involved, the model is expressed as follows:

$$Y_k = b_{k_0} + \sum_{i=1}^5 b_{k_i} X_i + \sum_{i=1}^5 b_{k_{ii}} X_i^2 + \sum_{i \neq j=1}^5 b_{k_{ij}} X_i X_j \quad \text{----- (2)}$$

where b_{k_0} was the value of fitted response at the center point of design, i.e., point (0,0,0), and b_{k_i} , $b_{k_{ii}}$, and $b_{k_{ij}}$ were the linear, quadratic and cross-product regression terms, respectively and Y is the response.

2.4. Data analysis

Multiple regression analysis was conducted for fitting the model represented by the equation to the experimental data. Maximization or minimization of the polynomial thus fitted was performed by numerical technique, using the mathematical optimizer procedure of Quattro Pro12 of Word Perfect Office 12 (M/s Corel Corporation, USA) that deals with constraints. The mapping of the fitted response was achieved using STATGRAPHICS Centurion XV version 15.1.02 (M/s StatPoint Inc., USA). The response surfaces and contour plot for these models were plotted as a function of two variables, while keeping other variables at the optimum level.

RESULTS AND DISCUSSION

3.1. Diagnostic checking of the fitted model

The coefficient of determination (R^2) is the proportion of variability in the data explained by the diagnostic checking of the fitted model and larger values of R^2 indicate a better fit of the model of the data. Regression analyses for different models indicated that the fitted quadratic models accounted for more than 96.0% of the variations in the experimental data, which were found to be highly significant. The experimental data were fitted to a second – order polynomial regression model containing linear, quadratic and interaction using the same experimental design software. The regression equation obtained after analysis of variance gives the level of extent of conversion of novolac resin as a function of the different process variables. All terms regardless of their significance are included in the following eqⁿ.

$$p = 0.71963 + 0.04772X_1 + 0.05061X_3 - 0.02478X_4 + 0.01944X_5 - 0.00842X_1^2 + 0.0234234X_3X_4 + 0.01708X_3X_5 + 0.03154X_5^2 \quad (3)$$

Where X_1 , X_2 , X_3 , X_4 and X_5 represent coded values of duration, pH , amount of substrate, nitrogen source and carbon source respectively and p is the response variable (maximum production of keratinase in Unit per 100ml).

The estimated effects were used to plot a standardized Pareto Chart for the model (Fig.1), the chart consists of bars with lengths proportional to the absolute values of the estimated effects divided by their standard values. The chart includes a vertical line at theoretical t -value for a 95% confidence level. A bar crossing this vertical line corresponds to a factor or combination of factors that have a significant effect in the response. The regression coefficients are shown in Table 3, as well as the correlation coefficient obtained for the model. The correlation coefficient for extent of conversion, p , ($R^2 = 0.95$) is quite satisfactory for response surfaces.

Table 3: Estimated coefficients of fitted quadratic equation for response based on t -statistics.

Coefficients	Estimated coefficient
b_{k0}	0.71963
b_{k1}	0.04772
b_{k3}	0.05061
b_{k4}	-0.02478
b_{k5}	0.01944
b_{k11}	-0.00842
b_{k34}	0.02342
b_{k35}	0.01708
b_{k55}	0.03154

3.2. Analysis of a variance

When a model has been selected, an analysis of a variance is calculated to assess how well the model represents the data. An analysis of a variance for the response is presented in Table 4. To evaluate the goodness of the model, a F -value test was conducted. The F -value for keratinase production was 2.22. On this basis, it can be concluded that the selected model adequately represents the data for keratinase production. From analysis of residuals, it is possible to conclude that they were randomly distributed around zero, and there was no evidence of outliers.

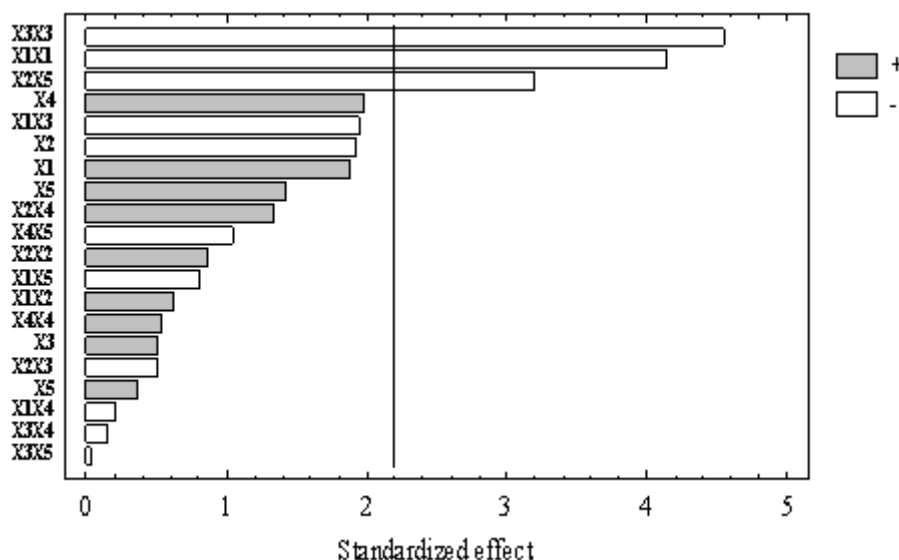

Fig.1: Standard Pareto chart for the estimated effects of extent of conversion, *p*

Table 4: Analysis of variance for the proposed model.

Keratinase production	Source of variation	df	Sum of Squares	Mean Square	F – value
<i>p</i>	Regression	20	0.40644	0.020322	2.22
	Residual	11	0.10075	0.009159	
	Total	31	0.50718		

3.3. Effect of process variables on extent of conversion

Model was useful in indicating the direction in which to change variables in order to maximize keratinase production. The optimum conditions to yield maximum keratinase production are presented in Table 5. The optimum value of *p* was found to be 0.927 which was higher than the highest value amongst the calculated values based on the experimental design. The response surfaces in Figs. 2-11 is based on the aforesaid model for *p* (Eq. 2) with three variables kept constant at the optimum level and varying the remaining two within the experimental range. The surface plot along with the contour plot of keratinase production (*p*) as a function of a duration and *pH* has been shown in Fig. 2. It is clear from the figure that the increase in duration or *pH* beyond the optimum value of extent of conversion increased the value of *p*. Further, at fixed level of duration, the change of *p* showed a linear pattern with amount of substrate and vice-versa. The change of *p* showed linear pattern with duration and amount of substrate (Fig. 3). Similar effect was observed with duration and nitrogen source (Fig. 4). The carbon source of medium changed extent of conversion in parabolic pattern with duration (Fig. 5). Also, at fixed level of duration, the effect of carbon source on *p* was found to be uniformly increasing. Fig. 6 showed the surface and contour plots of *p* as a function of *pH* and amount of substrate whereas Figs 7-8, demonstrated the effect of *pH* with nitrogen source or carbon source, respectively, on the extent of conversion, *p*. The increase of *pH* and nitrogen source decreased the value of *p* upto an optimum value and then increased. Fig 7 and 8 showed the linear and parabolic pattern respectively.

The surface plot of *p* as a function of amount of substrate and nitrogen source is shown in Fig. 9. The figure clearly evidenced that the amount of substrate and nitrogen source affected *p* in a parabolic pattern. Change of amount of substrate with carbon source (Fig. 10) demonstrated that the extent of conversion increased progressively with carbon source. The value of *p* linearly decreased with nitrogen source and increased with carbon source (Fig. 11).

Table 5: Optimum conditions for maximum keratinase production, *p*.

Process variables	Coded values	Uncoded values
Duration (days)	0.2	12.8
<i>pH</i>	1.0	10.0
Amount of substrate (mg)	-0.02	199
Nitrogen source (%)	-1.5	3.5
Carbon source (%)	2.0	3.0

Maximum value of keratinase production, p = 0.927 percent

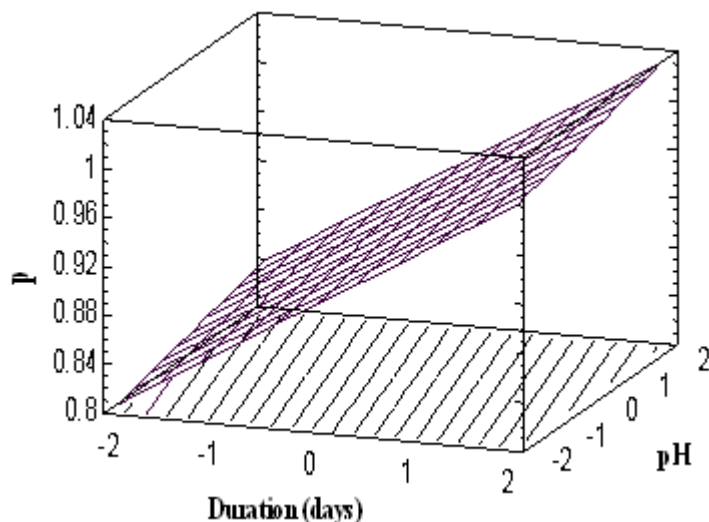

Fig.2: Surface and contour plot between duration and pH.

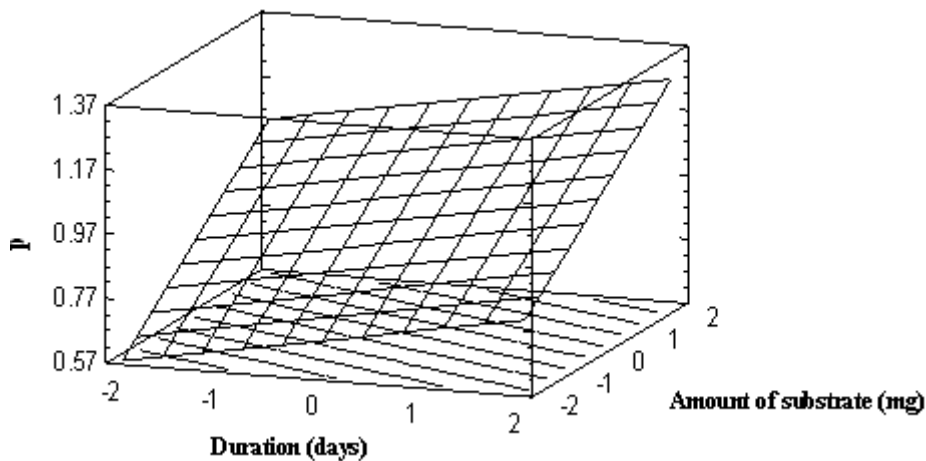

Fig.3: Surface and contour plot between duration and Amount of substrate.

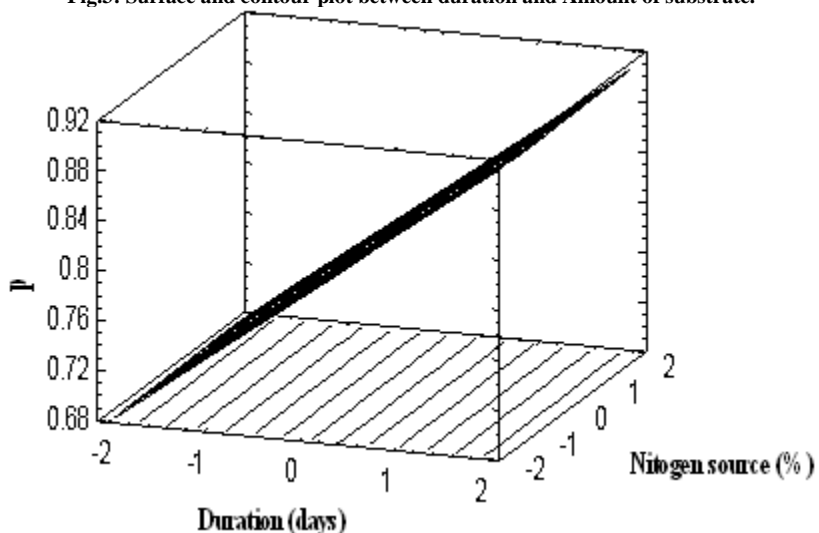

Fig.4: Surface and contour plot between duration and nitrogen source.

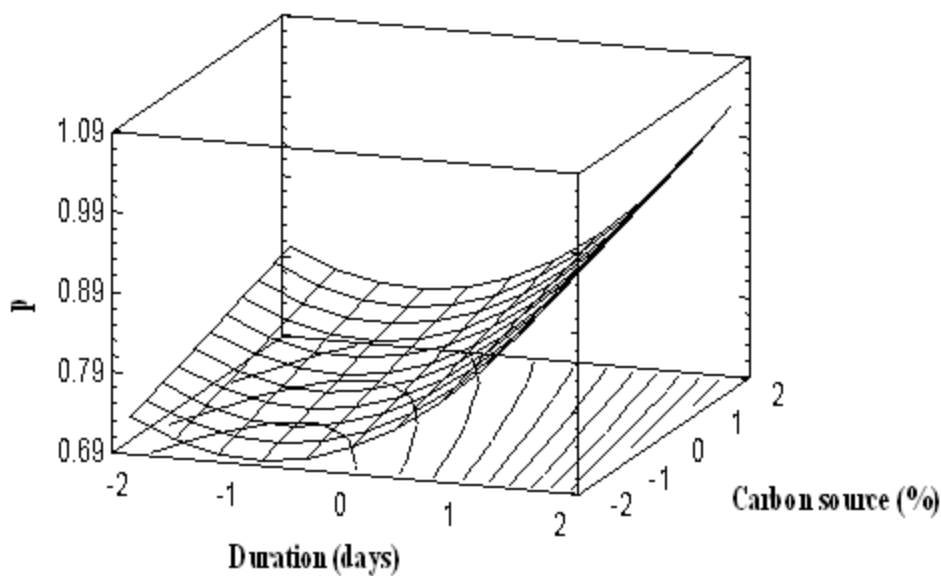

Fig.5: Surface and contour plot between duration and carbon source.

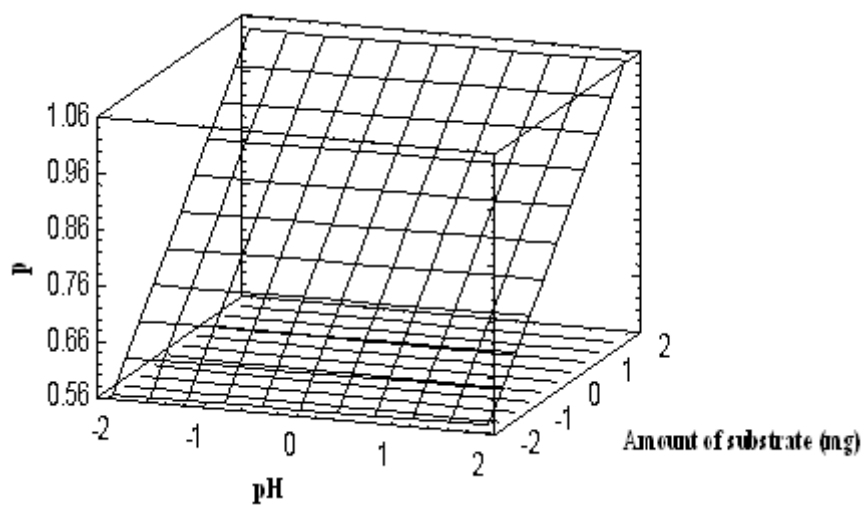

Fig.6: Surface and contour plot between pH and amount of substrate.

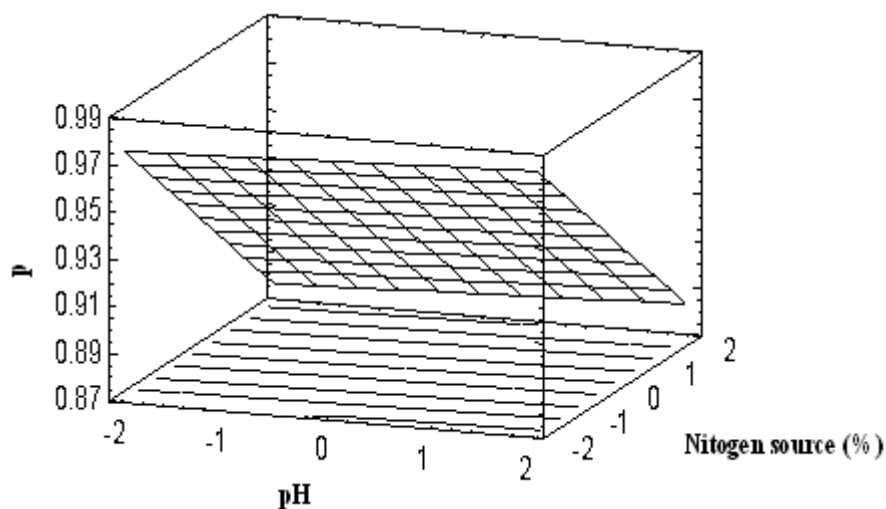

Fig.7: Surface and contour plot between pH and nitrogen source.

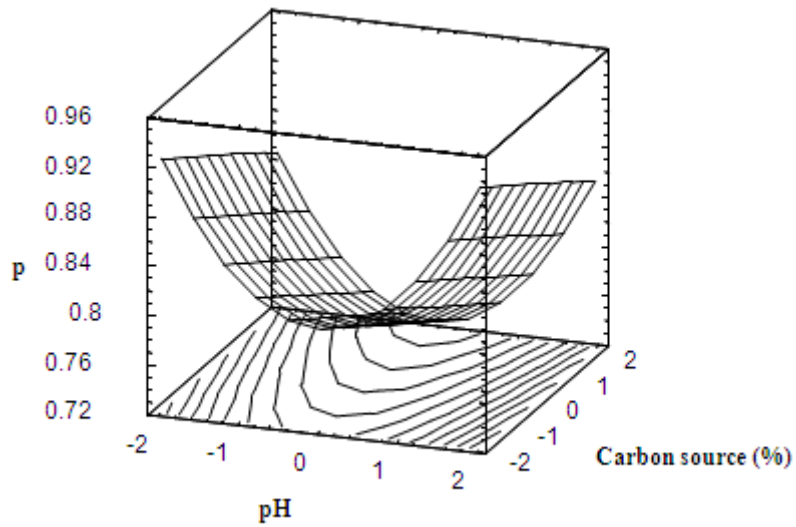

Fig.8: Surface and contour plot between pH and carbon source.

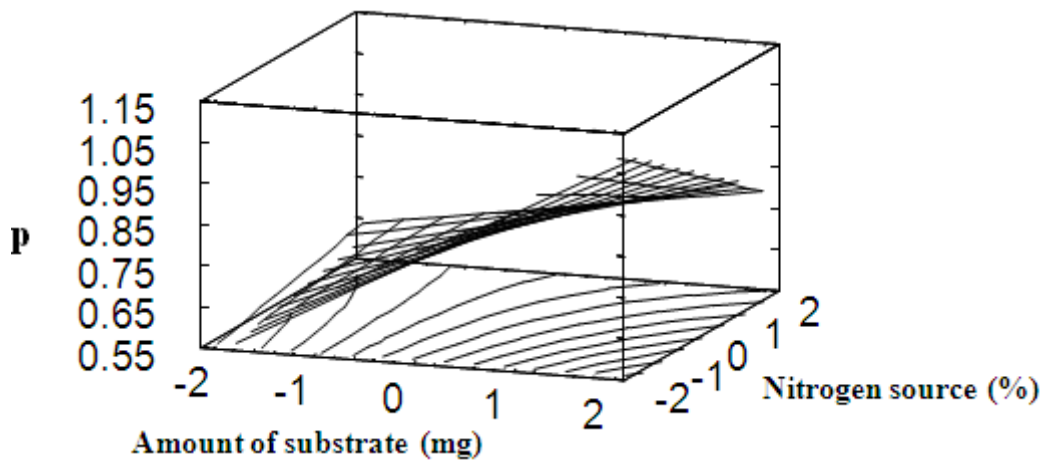

Fig.9: Surface and contour plot between amount of substrate and nitrogen source.

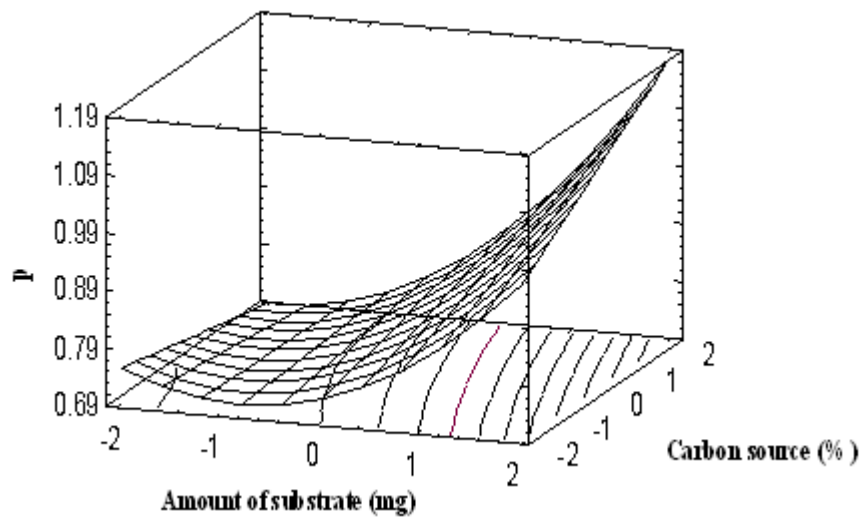

Fig.10: Surface and contour plot between amount of substrate and carbon source.

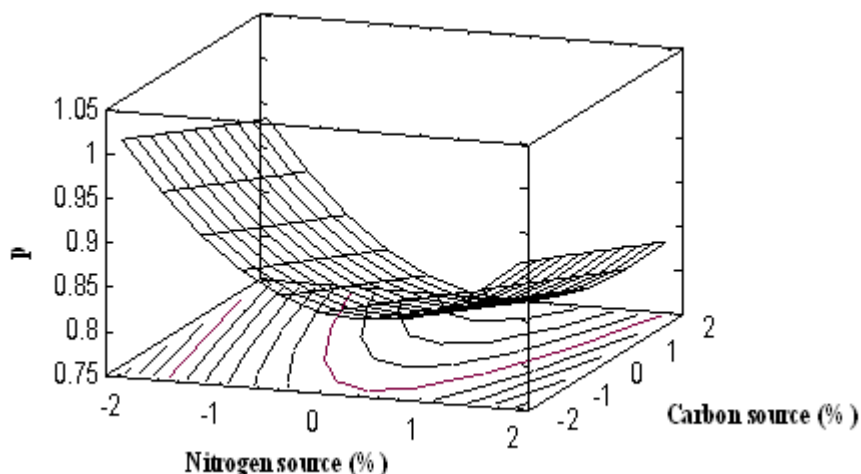

Fig11: Surface and contour plot between nitrogen source and carbon source.

CONCLUSION

The process parameters applied in this study demonstrated a good performance. The CCD, regression analysis and response surface method were effective in identifying the optimum condition of keratinase production. Important information was obtained through the RSM. It may conclude that using RSM, with a minimum number of experiments, can effectively optimize the keratinase production. The maximum keratinase production (92.7 percent) was predicted when the duration 12.8 day, 10 pH, amount of substrate 199mg, nitrogen source 3.5% and carbon source 3%. The maximum keratinase production was achieved (92.7%) at the optimum process conditions. These predicted values for optimum process conditions were in good agreement with experimental data.

Acknowledgement

Financial support for this work was given by DST New Delhi in the form of JRF & SRF to Jitendra Kumar.

REFERENCES

- [1] S.E. Agarry, B.O. Solomon, S.K. Layokun, *African J. Biotechn.*, **2008**, 7, 2409-2416.
- [2] K. Aunstrup, O. Anderson, E.A. Falch, T.K. Nielsen, In: H.J. Peppler, D. Perlman (Ed.) Production of microbial enzyme, microbial Technology, Vol. 1 (Academic Press, NewYork, **1979**) 282.
- [3] P. Bressollier, F. Letourneau, M. Urdaci, B. Verneuil, *Applied and Environmental Microbiology*, **1999**, 65, 2570–2576.
- [4] B. Bockle, B. Galunsky, R. Muller, *Applied and Environmental Microbiology*, **1995**, 61, 3705–3710.
- [5] I. Benedek, I. Fragmenta mycologiae, *Mycopathol.*, **1962**, 16, 104-106.
- [6] G.E.P. Box, W.G. Hunter, J.S. Hunter; Statistics for Experimenters –An Introduction to Design, Data Analysis and Model Building, New York, John Wiley & Sons, **1978**.
- [7] G.E.P. Box, N.R. Draper; Empirical Model – Building and Response Surfaces, USA, **1987**.
- [8] G.E.P. Box, D.W. Behnken, *Technometrics*, **1960**, 2, 455-475.
- [9] G.E.P. Box, N.R. Draper, *J. Am. Stat. Soc.*, **1959**, 54, 622-654.
- [10] J.S.M.S. Carla, I.C. Roberto, *Proce. Biochem.*, **2001**, 36, 1119-1124.
- [11] W.S. Chow, Y.P. Yap, *Polymer Letters*, **2008**, 2, 2-11.
- [12] W.G. Cochran, G.M., Cox Experimental Designs. R.A. Bradley, D.G. Kendall, J.S. Hunter, G.S. Watson, Eds; 2nd edition (John Wiley & Sons, New York, **1957**) 335.
- [13] W. Dasu, T. Panda, *Biopro. Engg.*, **2000**, 22, 45-49.
- [14] C.H. De Toni, M.F. Richter, J.R. Chagas, J.A. Henriques, C. Termignoni, *Can. J. Microbiol.*, **2002**, 48, 342–348.
- [15] I.N.S. Dozie, C.N. Okeke, N.C. Unaeze, *World J. Microb. & Biotech.*, **1994**, 10, 563–567.
- [16] M. Elibol, D. Ozer, *Proce. Biochem.*, **2002**, 38, 367-372.
- [17] S.L.C. Ferreira, R.E. Bruns, E.G. Paranhos da Silva, W.N. Lopes dos Santos, C.M. Quintella, J.M. David, J. Bittencourt de Andrade, M.C. Breitzkreitz, I.C.S.F. Jardim, B.B. Neto, *J. Chromat. A*, **2007**, 1158, 2–14.
- [18] A.B. Friedrich, G. Antranikian, *Appl. Environ. Microbiol.*, **1996**, 62, 2875-2882.
- [19] J. Grum, J.M. Slabe, *J. Mater. Proc. Tech.*, **2004**, 155–156, 2026–2032.
- [20] F.A. Hasmann, A. Pessoa, I.C. Roberta, *Biotechn. Techniq.*, **1999**, 13, 239-242.

- [21] R.N. Kumar, R. Nagarajan, F.C. Fun, P.L. Seng, *Euro. Polym. J.* 36, 2491-2497.
- [22] R.K.S. Kushwaha, *Mycosen*, **1983**, 26, 324-326.
- [23] X. Lin, G.D. Inglis, L.J. Yanke, K.J. Cheng, *J. Indust. Micro. & Biotech.*, **1999**, 23, 149-153.
- [24] D.C. Montgomery, *Design and analysis of experiments*, 3rd ed. New York: Wiley, **1991**.
- [25] I.S. Maddox, S.H. Richert, *J. Appl. Bacteriol.*, **1977**, 43, 97-204.
- [26] A.A. Onifade, N.A. Al-Sane, A.A. Al-Musallam, S. Al-Zarban, *Bioresour. Technol.*, **1998**, 66, 1-11.
- [27] P. Ramnani, R. Gupta, *Biotechnol. Appl. Biochem.*, **2004**, 40, 191-196.
- [28] K.J. Rao, C.H. Kim, S.K. Rhee, *Proce. Biochem.*, **2000**, 35, 639-647.
- [29] A. Riffel, F. Lucas, P. Heeb, A. Brandelli, *Arch. Microbiol.*, **2003**, 179, 258-265.
- [30] P.M.M. Schrooyen, R.V. Meer, G. Kruifc, *Proc. Nutr. Soc.*, **2001**, 60, 475-479.
- [31] M.C.D. Souza, I.C. Roberto, A.M.F. Milagres, *Applied Microbi. & Biotech.*, **1999**, 52, 668-672.
- [32] P.G. Sohnle, D.K. Wagner, In: J. Lederberg (ed.) *Fungal infections, cutaneous*, *Encyclopedia of microbiology*, 2nd edn. (Academic, San Diego, **2000**) 451-459.
- [33] C. Techapun, T. Charoenrat, M. Watanabe, K. Sasaki, N. Poosaran, *Biochem. Engg. J.*, **2001**, 12, 99-105.